

OPTOFLASH

NEXT GENERATION
PRECISION
MEASUREMENT
SOLUTION



MARPOSS

OPTOFLASH is a flexible optical measuring system, fast and precise. Optoflash is the perfect solution for accurate quality control in the laboratory as well as in the production environment.



There is a wide measurement toolkit library that can easily solve any of the most typical measurement problems. These include dimensional, position and form measurements both in static and dynamic mode. The library also includes thread measurement functions.

Optoflash is based upon **state-of-the-art area image sensors** and it can perform many micrometric-precision checks on parts with an **unprecedented speed**. Optoflash uses multiple image sensors integrated in fixed positions across the product structure to cover the entire measurement range. This gives the advantage that neither the image sensors nor the part being measured must travel along the Z-axis.

automotive

electronics

aerospace

fasteners

medical

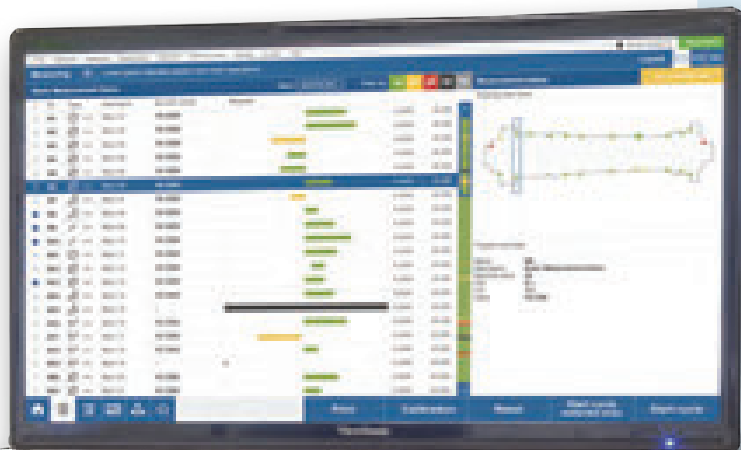

APPLICATION EXAMPLE



- 9x Dynamic Diameters
- 2x Arc Radii
- 4x Axial Distances
- 3x Groove Diameters
- 1x Cylindricity
- 1x Chamfer Angle

MEASURING CYCLE TIME: **5.6 seconds!**

Optoflash is the world's-first optical measuring unit based on side-by-side 2D image architecture.

This means that images that are acquired by different sensors are perfectly combined together in order to generate one single resultant image of the part with zero discontinuities and no gaps at the stitching edges.

As a result Optoflash is capable of measuring parts up to 300 mm in length without any vertical movement of the sensors or the part itself.

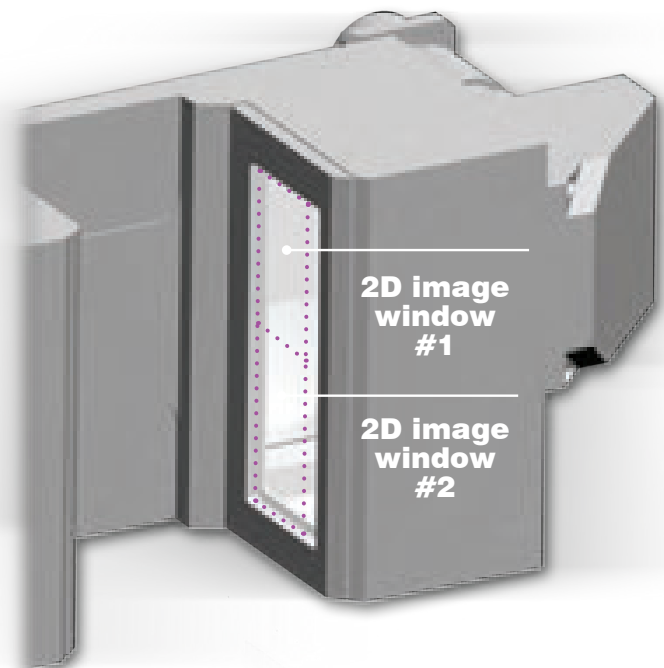

FAST

With the absence of Z-axis motion the optical acquisition of the complete part - which consumes time on other systems - is performed almost instantaneously on the Optoflash.

Therefore its cycle time is impressively fast. For example, it executes 100 static measurements in just 2 seconds irrespective of how the measurement sections are distributed along the shaft length!

DURABLE

Fixed position sensors means there is no mechanical stress.

Metrological performance of the Optoflash is consistent and stable over millions of cycles. There are also minimal maintenance requirements.

MEASUREMENT PRECISION AND «FLASH» CYCLE TIME: ALL-IN-ONE

The 2D image architecture sets a new benchmark in the measuring industry, with significant advantages for operators.

1

Unrivalled measuring speed, thanks to the no z-axis movements. Full 2D optic.

2

Image consistency: complex profiles and part geometries are acquired inside the same image frame, so removing from measurements any, even negligible machine mechanical error.

3

Axial run-out: the 2D image frame allows for the entire surface to be captured dynamically, at each angle, during the part rotation. That's why Optoflash makes optical TIR better than any other traditional optical solution.

4

Thru-holes measurement: only a few milliseconds are necessary between the image acquisition and the thru-hole measurement execution.

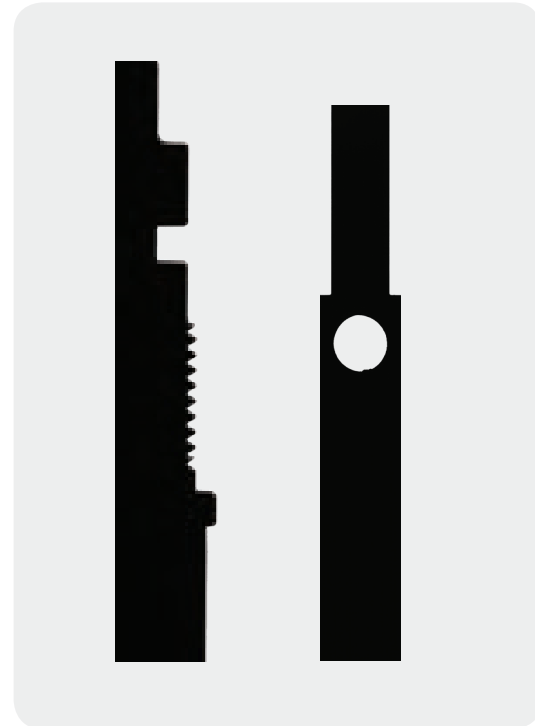

FASTENER QUALITY CONTROL

Screws, pins or rivets can be easily and quickly measured with the Optoflash.

The standard measurement toolkit includes threads analysis: maximum and minimum diameter, pitch diameter, pitch value, thread angle, thread linearity, total thread length.

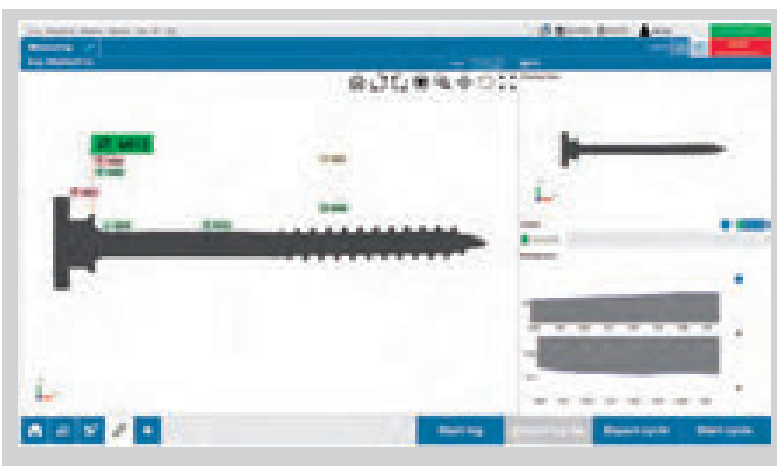

TURBOCHARGERS

Thanks to the 2D image acquisition, Optoflash is a superior solution for measurements on the turbocharger shaft.

In fact, Optoflash acquires the entire part profile into a single 2D image, which enables it to achieve the maximum acquisition accuracy of the blade profile and a superior measuring speed at the same time. Optoflash is normally 2 times faster than traditional linear scanning solutions.

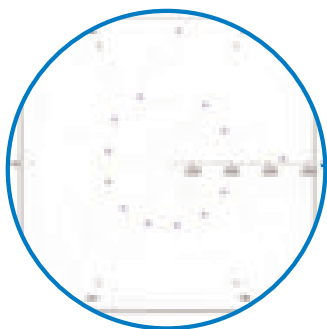
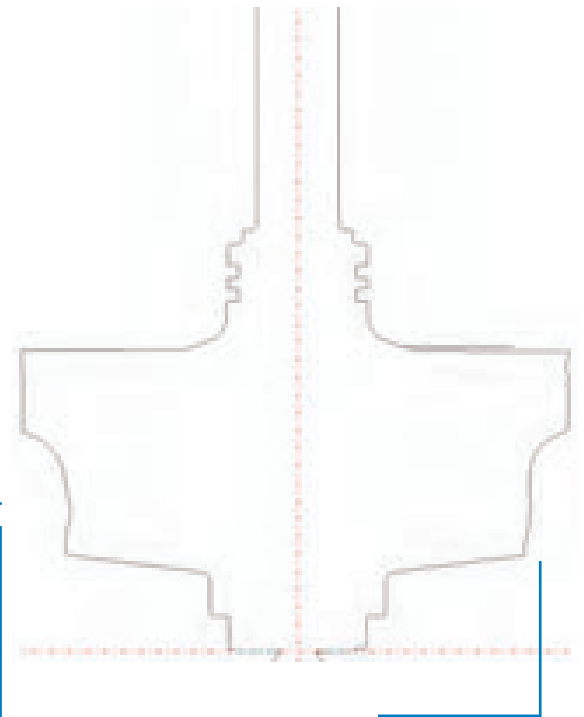
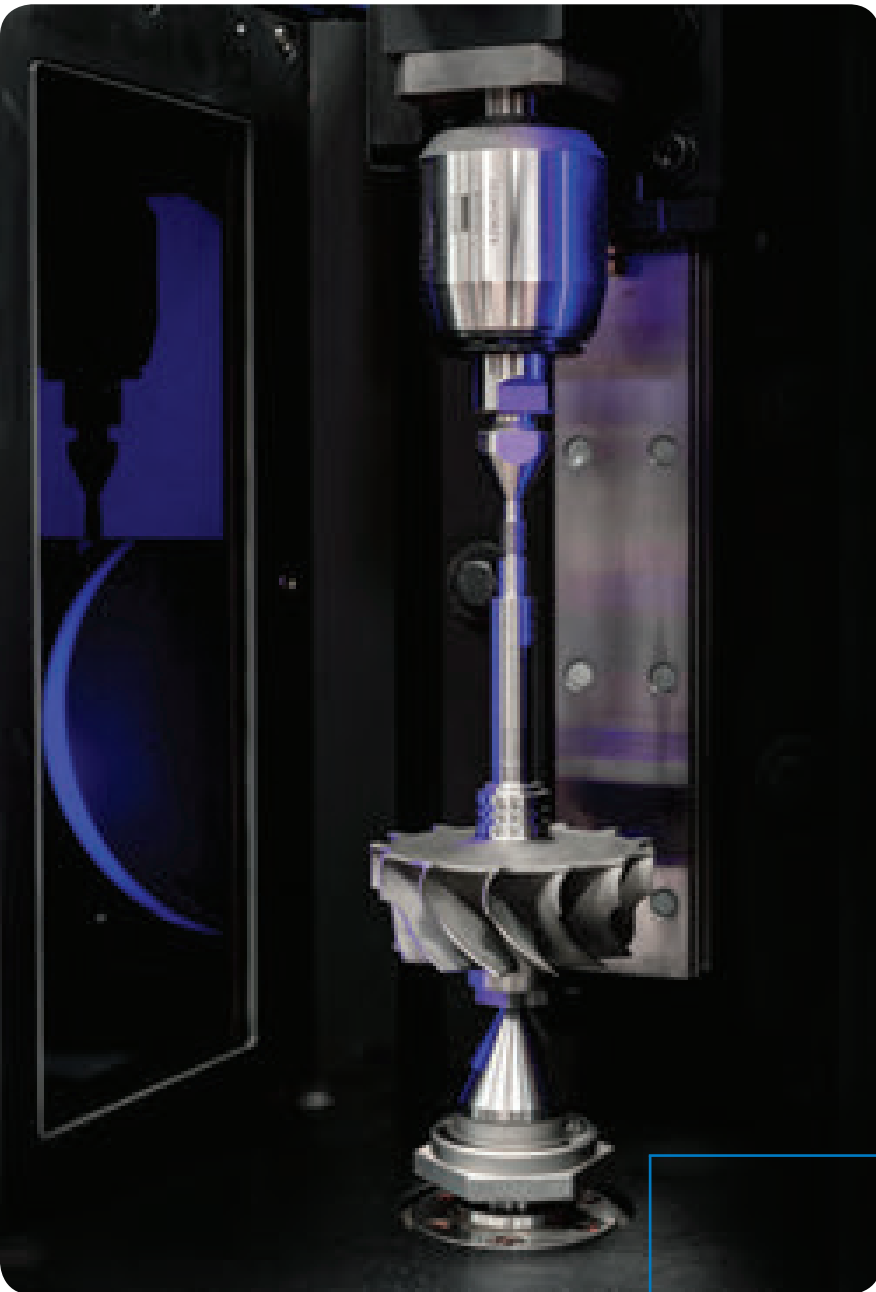

**Radial run-out,
diameters, concentricity,
blade-by-blade results**

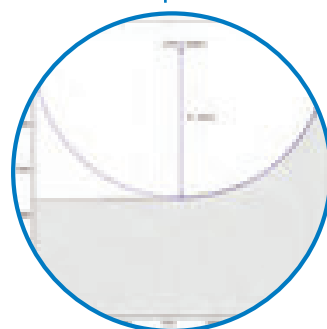

**Radius measurement,
blade-by-blade results**

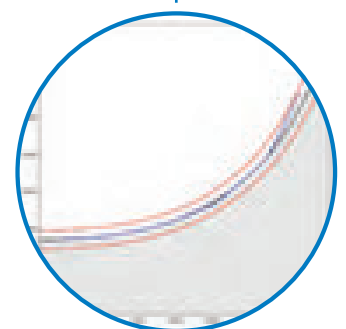

**Profile error,
blade-by-blade results**

THE ULTRA-HIGH RESOLUTION MODEL FOR ULTRA-SMALL SIZE PARTS

Optoflash XS is Marposs' latest addition to the 2D optical measuring solutions, designed to meet the requirements of the precision mechanical devices industry, as well as the medical implants industry.

ULTRA-HIGH IMAGE RESOLUTION

Optoflash XS offers a superior level of image pixel density. It is the solution for measuring small parts and tight tolerances

COMPACT SIZE SOLUTION

Designed to be integrated in the production environment as well as in the lab
Optoflash XS is an all-in-one product, integrating the optics processing unit and user interface

SUPERFAST

Operator just places the part into position on the measuring holder, and press the «Start» button.
In just 2 seconds, the part is completely measured



PRECISION MECHANICAL DEVICE INDUSTRY

Optoflash XS meets the requirements of the precision mechanical device industry. For instance, Optoflash XS can easily measure small chamfers or grooves, even below 100 μm extension, or very small changes of diameter along the part axis.

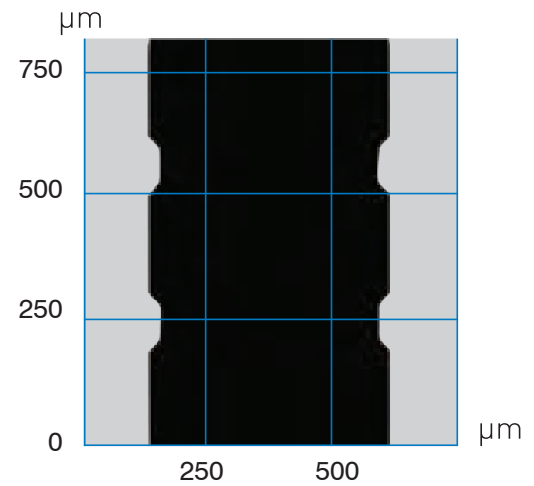

MEDICAL INDUSTRY

Flexibility makes the Optoflash XS a cost-effective solution for quality controls in the manufacturing of tools or implants for the medical industry. Should it be plastic molded parts or high precision dental implants, Optoflash XS delivers performance in speed and measuring precision. It is capable to switch from one part type to a completely different one **in the matter of a click.**

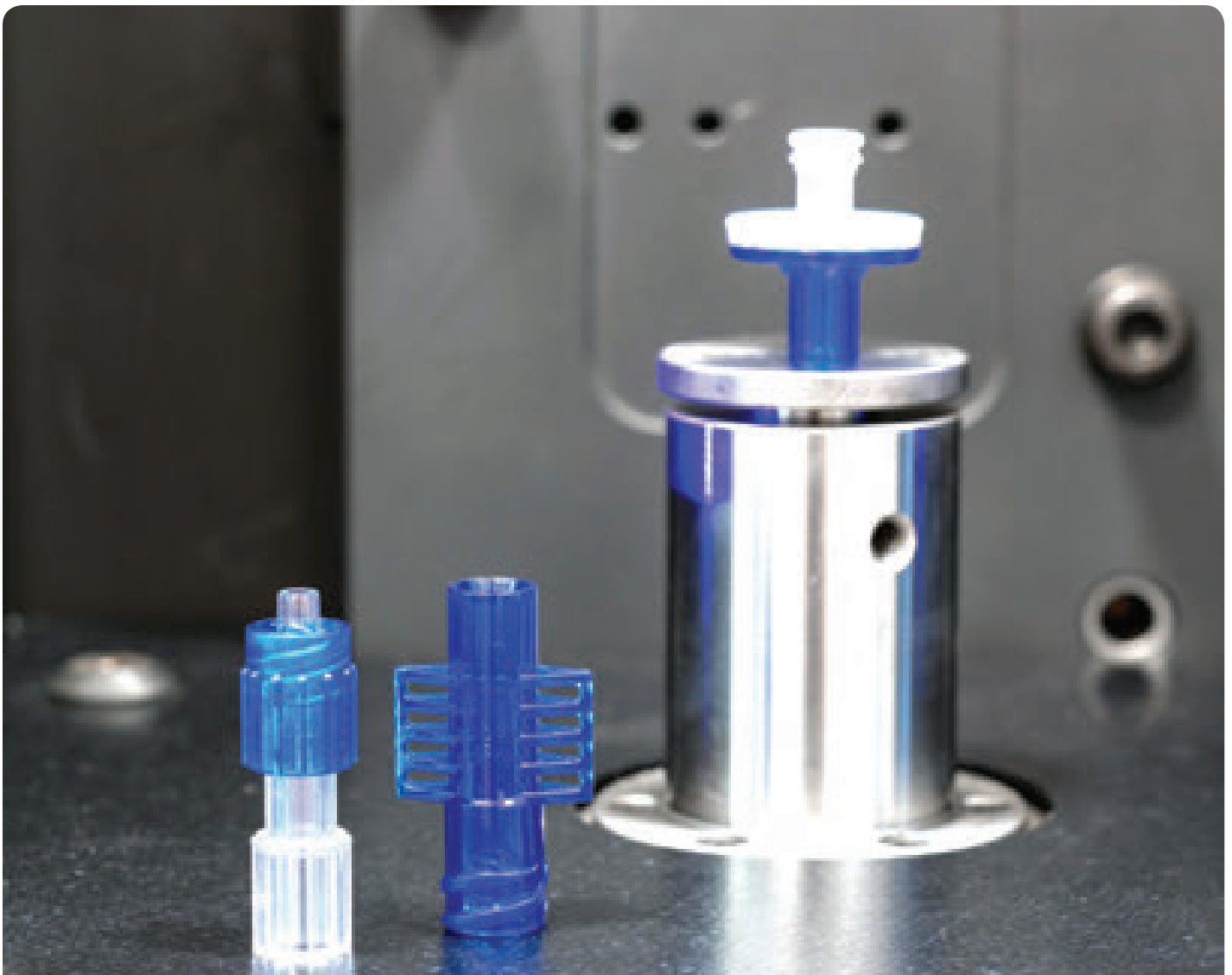

Optoflash is designed for ease of use: there is an open loading area with no obstructions and an ergonomic tailstock system for easy part clamping. The graphical user interface - via a touchscreen monitor - provides excellent ease of use.

One-click
measuring cycle activation

Connectivity
integrated USB hub with 7 available ports for easy connection of printers, code readers or external devices memory

Monitor
- on a flexible arm -
can be installed on either side of the unit



Part loading

Part type change

Correct part loading indicator

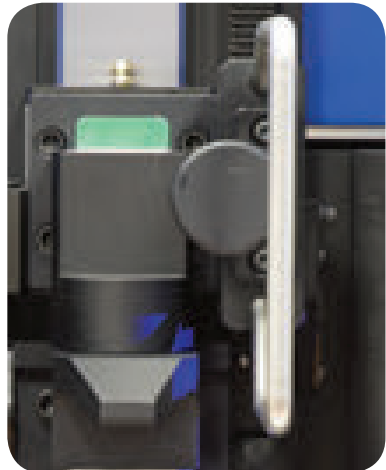

Optoflash is equipped with a state-of-the-art graphical user interface.

EASY TO USE

Eliminate training costs with an intuitive user interface. Features like easy interpretation of the measurement results, part detail images and graphical setups. Anyone can use and also configure new measurements on the Optoflash.

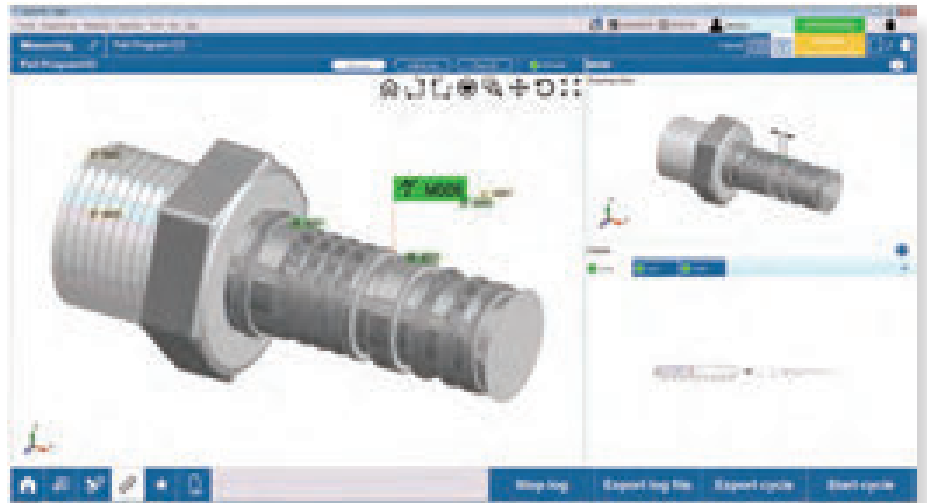

NEW FEATURES

As measurements are archived, a smart search function provides part detail review by images and trend visualization.

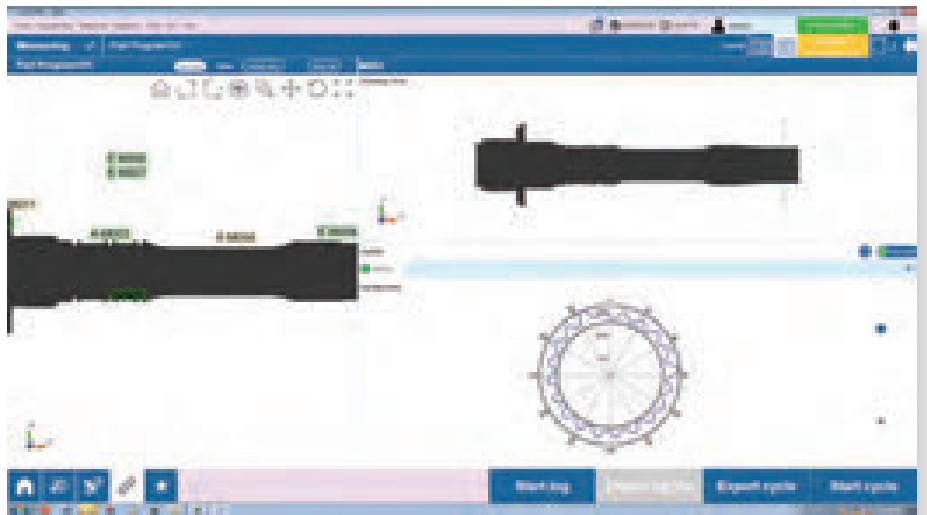

SUPERIOR SETUP FLEXIBILITY

Allows the Optoflash to fit a large variety of application requirements with easy actions.

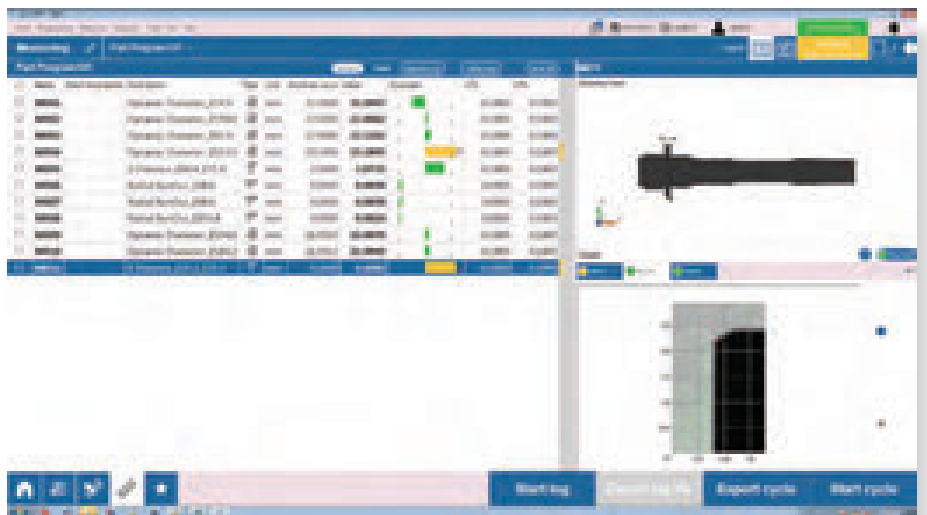

OPTOFLASH MODELS



MEASURING RANGE [MAX PART DIMENSION]
LENGTH (mm)
DIAMETER (mm)

33 [33]
20 [90]

MAX PART WEIGHT (Kg)

1

MEASURING UNCERTAINTY 1
LENGTH (mm)
DIAMETER (mm)

U95 (2+L[mm]/200) μ m
U95 (1+D[mm]/200) μ m

PART LOADING MODE

MANUAL AND AUTOMATIC (BY ROBOT)

PART ROTATION

OPTION

MEASUREMENTS MODE

STATIC AND DYNAMIC

**DIMENSIONS
OF THE MEASURING SYSTEM**
W x D x H (mm)

610 x
545 x
400

1) Calculated following DIN 1319 part 3 / ISO norms on a reference master.
Ambient temperature at $20^{\circ}\text{C} \pm 1\text{K}$ with a maximum variation of 0.5K/h . Part temperature $20^{\circ}\text{C} \pm 1\text{K}$.

PART CLAMPING OPTIONS

PLATE



CHUCK



CENTER TIPS





100 [100]
60 [90]

200 [200]
60 [90]

300 [300]
60 [90]

6

U95 (2+L[mm]/200) μm
U95 (1+D[mm]/200) μm

MANUAL AND AUTOMATIC (BY ROBOT)

OPTION

STATIC AND DYNAMIC

925 x
615 x
640

925 x
615 x
740

925 x
615 x
840

TYPICAL MEASURING TASKS

Dimensional, position, form measurements

- ✓ Cylindricity
- ✓ Coaxiality
- ✓ Straightness
- ✓ Roundness
- ✓ Flatness
- ✓ Symmetry
- ✓ Parallelism
- ✓ Perpendicularity
- ✓ Cam profile

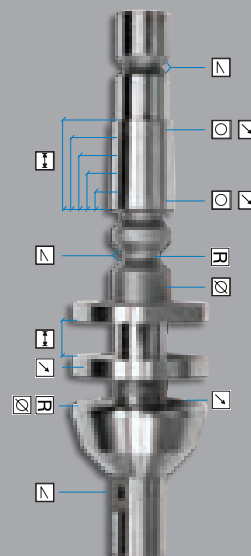

- ✓ Thread inspection
- ✓ Diameter
- ✓ Length
- ✓ Radius
- ✓ Chamfer
- ✓ Angle
- ✓ Radial run-out
- ✓ Axial run-out
- ✓ Concentricity

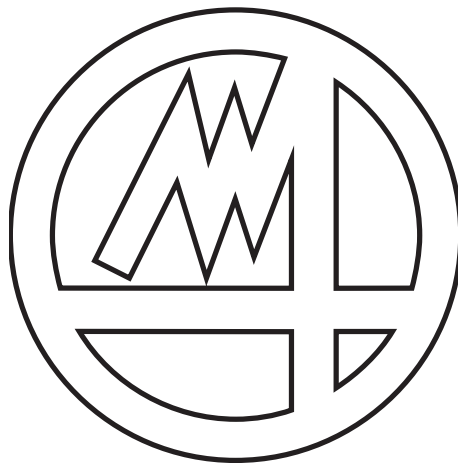

MARPOSS

For a full list of address locations, please consult the Marposs official website

Edition 04/2019 - Specifications are subject to modifications © Copyright 2017-2019 MARPOSS S.p.A. (Italy) - All rights reserved.

MARPOSS, logo and Marposs product names/signs mentioned or shown herein are registered trademarks or trademarks of Marposs in the United States and other countries. The rights, if any, of third parties on trademarks or registered trademarks mentioned in the present publication are acknowledged to the respective owners.

Marposs has an integrated system to manage the Company quality, the environment and safety, attested by ISO 9001, ISO 14001 and OHSAS 18001 certifications.